

## PART 5

---

# EXTREME CAT - 6 LITRE RULES

### EXTREME CAT - CLASS SPECIFIC RULE

01. HULL MEASUREMENT
02. HULLS MINIMUM/MAXIMUM LENGTHS AND WEIGHTS
03. MINIMUM FLOTATION
04. HULL/DECK REQUIREMENTS
05. MANDATORY EQUIPMENT
06. ENGINES
07. GENERAL ENGINE MODIFICATION RULES
  - 07.01. NON EPA/CARB PERMITTED MODIFICATIONS
  - 07.02. MODIFICATIONS NOT PERMITTED (EPA/CARB)  
OUTBOARD ENGINES
08. GEARBOX & WATER PICK UP
09. PROPELLORS
10. SCORING SYSTEM
  - 10.01. 21-25 BOATS: 5 BONUS POINTS
  - 10.02. 26-30 BOATS: 10 BONUS POINTS

**THE FOLLOWING WPPA RULE SECTIONS ARE  
ALSO APPLICABLE TO EXTREME CAT - 6 LITRE  
UNLESS OTHERWISE STATED**

**INTRODUCTION**

Part 1	Fundamental Rules
Part 2	General Application
Part 3	Jurisdiction
Part 4	Class 1 Event Rules
Appendix 1	Safety Procedures and Guidelines
Appendix 2	On Water Procedures and Guidelines
Appendix 3	On Land Procedures and Guidelines
Appendix 4	Technical Notes
	03. Crew Safety
	04. Drawings and Measurement
	05. Reinforced Cockpit Area and Canopy
Appendix 5	Turn Bouys Clarification Drawings

### EXTREME CAT - CLASS SPECIFIC RULE

#### Hull Dimensions Requirements etc.

The WPPA Extreme Cat class strictly prohibits the use of mono hulls and inboard engines.

WPPA Cat Class racing shall only permit the use of boats powered by Outboard engines.

#### **01. HULL MEASUREMENT**

All hull measurements are to be taken while the boat is ashore.

The length must be measured between perpendiculars of the external molded length of the boat, taken at the extreme bow and the rear most planning surface (the rear most part of the keel) including all hull planning steps (regardless of height), but excluding trim tabs, either fixed or movable.

Hull extensions beyond the transom shall be deemed to be “fixed rim tabs” and shall not be included in the measured length.

Hull extensions added to the bow and/or any extending parts, rubbing strakes, fenders, outboard motor spacing brackets, stabilising trim tabs and rudder assemblies are not to be included in the measured length.

When defining “extreme bow”, any form that constitutes the bow and its construction and contributes to the performance of the boat shall be included in the measured length. Any other attachment that is added to meet a minimum length requirement shall not be included in the measured length.

Should the trailing edge of the planning surface of a hull or sponson terminate with an angle greater than 15° measured between the keel and outer chine in plan view (birds eye view), such excess shall not be included in the measured length.

The beam measurement shall be taken at the widest part of the moulded hull, excluding any extending parts, rubbing strakes and/or fenders.

Trim tabs, either fixed or moveable, shall not exceed a length of 10% of the measured length of the hull.

Tunnel flaps shall not exceed a length of 10% of the measured length of the hull.

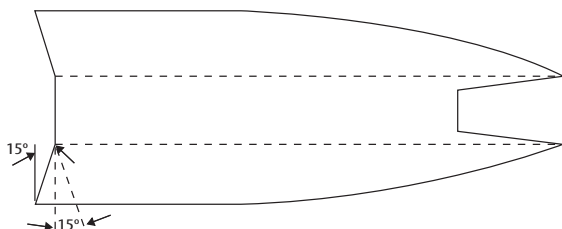

NOT GREATER THAN 15°

CATAMARAN IN PLAN VIEW

## 02. HULLS MINIMUM/MAXIMUM LENGTHS AND WEIGHTS

The WPPA X Cat class weight criteria for both Non EPA and EPA engines, is as follows:

	Non EPA 4101 - up to 6000cc	EPA up to Max 2 x 300hp
Max HP	—	600

All EPA engines must be approved by the WPPA Technical Director for eligibility if new to the X Cat series.

All weights and dimensions below refer to the use of both EPA and non EPA engines.

Min Length	7.6m
Max length	10.00m
Multi Min kg	1675kg
Add kg per m	110kg
Cube	
- Length	3.60m
- Width 1.20m	1.20m
- Height	0.46m
Bouyancy	
- GRP	550l
- Comp	300l

The minimum weight mentioned is for a boat with the mentioned minimum length. For boats longer than the minimum, the weight shall be increased according to the formula shown above.

Minimum weight is calculated as post race, including all safety equipment (except the crew and their helmets and life vests), residual fuel in tanks will be included in the minimum weight. Slings carried in the boat during the race will count as safety equipment. The boat must be empty of water.

### 03. MINIMUM FLOTATION

All boats shall contain a minimum volume of buoyancy permanently installed in the hull.

The minimum volumes measured in litres are mentioned in the chart.

If a boat is constructed of wood, the wooden weight content of the boat may be accepted as buoyancy as per the following formula : Wood weight in kg x 2 = litres of buoyancy.

### 04. HULL/DECK REQUIREMENTS

The deck must be able to bear the weight of a standing man (100 kg) at any point.

All cable and wiring deck exits should be watertight.

All boats shall be fitted with a well secured mooring cleat or tow bracket adequate for anchoring in a seaway and for towing at sea over a prolonged period.

The hook is to be fitted on a reinforced area designed for the purpose of towing a water laden hull.

Boats must be fitted with a minimum of three lifting eyes, either through deck or topside hull cleat type, suitably engineered to withstand lifting the boat fully equipped and fuelled with an adequate safety margin.

Each boat shall be equipped with a detachable strop assembly providing a single lifting point.

Boats must have fuel filling and fuelventing capabilities outside of the crew containment area.

Canopied craft are to have fuel tanks contained in sealed compartments from the hull and crew area to avoid leakage of liquid or vapour being released into the area being used by the crew. Fuel filling / fillers are to be outside of the crew compartments.

The fuel tank or tanks must be grounded to enable the discharge of static electricity.

Fuel tanks may be constructed as an integral component of the hull construction, or may be fabricated material suitably secured to the hull.

Purpose designed and constructed rubberised collapsible fuel cells may be used.

It is recommended that new boats are fitted with explosafe type fuel tanks.

### 05. MANDATORY EQUIPMENT

Any television equipment and/or telemetry equipment required by the WPPA or its contractors or associated equipment and is deemed to be mandatory and must remain in place at all times and maintained for the intended purpose.

When additional electric pumps are fitted to the fuel supply a fuel cut-off switch for the pump shall be fitted within reach of either crew member.

A manually operated bilge pump with the capability of pumping out any one of the watertight compartments.

In addition to the above minimum it is highly recommended to have any additional electric bilge pumps that appear appropriate.

An orange flag measuring at least 0.60 x 0.40 metres and the means of hoisting it, to indicate retirement.

A sharp knife suitable for cutting webbing, clothes or rope. The knife shall be suitably sheathed so as to protect crew members against accidental injury. It may be located in a fixed position in the cockpit adjacent to all crew members or, be separately carried on each crew member.

One diving-mask.

A radio capable of transmitting on the International distress frequency or race control frequency, must be carried in full operational condition.

Other items may be required as listed on the class scrutineering checklist.

### 06. ENGINES

The WPPA Technical Director may at any time request the substitution of any boats ECU for a standard stock control ECU held by the WPPA as a replacement on any boat for the duration of the event or race.

Existing Extreme Cat engine rules in place in the GCC Championship series are eligible.

Manufacturers new models EPA/CARB type engines may be used subject to the WPPA Technical committee approval. Only those that closely match exiting horse power capabilities will be considered. No modifications will be permitted.

All engines must conform to those entered and accepted on the WPPA measurement certificate.

Internal or external spraying of any substance into the airstream except fuel through the engines injection system is forbidden.

### 07. GENERAL ENGINE MODIFICATION RULES

Revolution counters, tachometers, water pressure and temperature gauges may be fitted to the engines.

Thermostats of the cooling circuit may be removed.

The use of an ECU outside of the official homologated standard offshore equipment or factory offshore standard, or any other device is not permitted. The modification and/or reprogramming is strictly forbidden.

Re-boring and fitting of oversize pistons is allowed as made available by the manufacturer for that model.

The steering bar and brackets may be reinforced as a safety measure.

It is also permitted to modify the standard engine cowling in order to facilitate the fitting of steering assemblies, provided that any openings are sealed so the engine can not pull in any additional air.

The rubber mounts of the engine may be changed or substituted.

A spring may be added to the intake butterfly valve.

All external (not contained within the powerhead) studs, screws, nuts, bolts and their washers are free as well as the method of locking them, providing there is no performance advantage.

Manufacturers available counter rotating gearboxes may be used.

The use of thrust blocks mounted on the lower unit and or on the boat is permitted.

Power Trim: a properly engineered system for altering engine trim whilst under way is permitted.

Transom brackets may be reinforced.

Lighter flywheels as made available by the manufacturer may be fitted as per homologation tolerances.

### 07.01. NON EPA/CARB PERMITTED MODIFICATIONS

Measurements not quoted in the homologation sheet may not be altered. If a detail cannot be verified with the aid of the pictures in the homologation sheet, the part in question can be compared to a corresponding stock part. In such a comparison it is only possible to approximate the comparable measurements as the manufacturing tolerances are not available.

A component may be machined in order to reach a specific dimension, which is quoted in the engine homologation file. A component for which the weight is quoted in the homologation file may be adjusted down to the weight, by machining or grinding provided that the area where metal is removed is the same as is used by the engine manufacturer.

This is known to be at the top or at the bottom, or both for piston connecting rods. Balancing of one or all piston connecting rods is permitted, as long as this is in accordance with manufacturer's procedures.

Polishing of connecting rods is not permitted. When the volume of the combustion chamber is specified in the homologation sheet, the cylinder head may be faced to achieve the volume allowed.

Mechanical ignition advance controls may be adjusted out of their normal setting range as long as the original parts are retained.

Mercury 2.5 EFI the exhaust plate may be removed.

Fuel flow regulator may be substituted. The original manufacturers fuel flow pressure must be in place and unchanged.

The fuel connector in the lower cover may be removed and the fuel hose from the fuel tank connected directly to the fuel pump. If this is done, the opening left after the connector and around the fuel hose must be sealed to prevent extra air entering inside of cover.

It is permitted to replace lubricating systems using oil tanks and oil pumps with lubrication oil mixed into the fuel. Caps or covers in the motor cover cannot be removed to provide extra air inlet.

### **07.02. MODIFICATIONS NOT PERMITTED (EPA/CARB) OUTBOARD ENGINES**

The following modifications are expressly NOT permitted.

- Blueprinting' of the powerhead.
- Alteration or modification of any powerhead components.
- Removal of material from the powerhead for any reason other than recognised (by the manufacturer) repair.

### **08. GEARBOX & WATER PICK UP**

The water intake may be repositioned; it must however remain on the gear case torpedo. The width or height of the gear case torpedo must not be changed. The length fore and aft may be increased. The rear edge of the water intake opening must not be further back than 30% of the total length of the modified gear case torpedo.

The original intake to the circulation pump may be filled in and faired.

For cooling purposes it is allowed to add material in front of the union leg, as long as the union leg width is not increased, except where the union leg meets the lower side of the anti-cavitation plate.

The modification shall be for cooling purposes only and shall form a radius. The radius shall be lengthwise parallel to the anti-cavitation plate. It is also permitted to add material to the centre section exhaust housing for the purpose of reducing noise.

Remote water pick-ups are not allowed.

Bearing carriers and propshafts may be changed from original.

All craft must be able to be manoeuvred ahead and astern and have neutral capability, operated by controls at the helmsman's position. This facility must be a permanent installation and able to be demonstrated as practical at any time.

### GEARBOX DRAWINGS

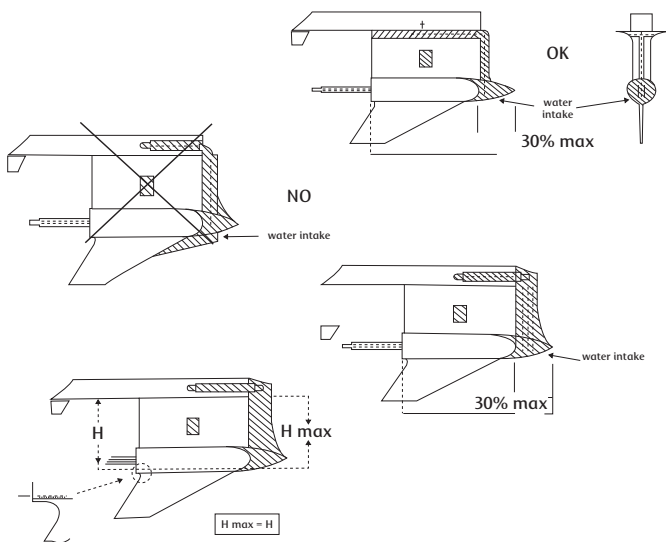

## 09. PROPELLORS

The use of forged propellers is strictly prohibited. Maximum number of permitted blades is 5.

### 10. SCORING SYSTEM

Unless otherwise specified, the following scoring system is to be adopted:

1 - 400 pts	11 - 22 pts
2 - 300 pts	12 - 17 pts
3 - 225 pts	13 - 13 pts
4 - 169 pts	14 - 9 pts
5 - 127 pts	15 - 7 pts
6 - 95 pts	16 - 5 pts
7 - 71 pts	17 - 4 pts
8 - 53 pts	18 - 3 pts
9 - 40 pts	19 - 2 pts
10 - 30 pts	20 - 1 pts

For events with more than 20 entries, the following bonus points should be given, so that all drivers can get points.

#### 10.01. 21-25 BOATS: 5 BONUS POINTS

Position 1) to 20) : should all have 5 extra bonus points

Position 21 : 5 points

Position 22 : 4 points

Position 23 : 3 points

Position 24 : 2 points

Position 25 : 1 point

#### 10.02. 26-30 BOATS: 10 BONUS POINTS

Position 1) to 20) : should all have 10 extra bonus points

Position 21 : 10 points

Position 22 : 9 points

Position 23 : 8 points

Position 24 : 7 points

Position 25 : 6 points

Position 26 : 5 points

Position 27 : 4 points

Position 28 : 3 points

Position 29 : 2 points

Position 30 : 1 point

85  
drivers

42  
boats

42  
teams

20  
countries

1  
class association



WPPA organise and manage Class 1 and Xcat World Series Powerboat Racing.  
WPPA is affiliated to UIM (World Governing Body for Powerboating).

[www.thewppa.com](http://www.thewppa.com)